



**EMS Physio Ltd.**

Grove Technology Park  
Downsview Road  
Wantage  
Oxfordshire OX12 9FE  
England

**User Manual**  
**VARITHERM WAX BATH**  
Model 17

**CE**  
0120



## ***General Information***

This manual provides the necessary information for the installation and operation of the Varitherm Wax Bath.

These instructions must be studied before putting the unit into operation.

The information contained in this manual is subject to change without notice.

No part of this manual may be photocopied, reproduced or translated into another language without the prior written consent of EMS Physio Ltd.

It is intended that the Varitherm Wax Bath is only used by qualified health professionals such as trained physiotherapists.

## ***Record of Amendments***

ISSUE	COMMENTS	DATE
4	CE Marking	25/06/1998
5	Revised	19/05/1999
6	Revised	25/04/2000
7	Revised	10/09/2001
8	Revised	05/07/2005
9	Revised Company Name	04/10/2006
10	Revised	01/10/2007
11	EMC Tables Added	05/02/2008

## EC Declaration of Conformity

EMS Physio Ltd  
Grove Technology Park  
Downsview Road  
Wantage  
Oxfordshire  
OX12 9FE  
United Kingdom

Declares that the following medical device is in conformity with the essential requirements and provisions of Council Directive 93/42/EEC and is subject to the procedure set out in Annex 2 of Directive 93/42/EEC under the supervision of Notified Body Number 0120, SGS United Kingdom Ltd.

Product Name            Varitherm Wax Bath

Model Number        17

Signature

A handwritten signature in black ink, appearing to read 'D. Smith', written over a light grey rectangular background.

Position                Technical Director

Date                     6 May 1998

## *Contents*

	page
Title	1
General Information	3
Record of Amendments	3
Declaration of Conformity to 93/42/EEC	4
Contents	5
Warranty	6
Introduction	7
Contraindications	8
Precautions	8
Technical Specification	9
Installation	10
Controls and Markings	11
Operating Instructions	14
Maintenance	15
Circuit Description	15
Disassembly and Assembly	16
Parts List	18
Circuit Diagram	21
EMC Tables	22

## ***Warranty***

This EMS Physio Ltd., (hereinafter called the company) product is warranted against defects in materials and workmanship for a period of two years from the date of shipment. The Company will at its option, repair or replace components which prove to be defective during the warranty period, provided that the repairs or replacements are carried out by the Company or its approved agents.

The Company will consider itself responsible for the effects on safety, reliability and performance of the product:-

only if assembly operations, re-adjustments, modifications or repairs are carried out by persons authorised by it,

only if the product is used in accordance with the instructions for use,

only if the electrical installation of the relevant room complies with the appropriate national requirements.

Should the product be returned to the Company for repair it must be sent carriage paid.

Consumable items, for example, electrodes, electrode covers and batteries, are excluded from the above warranty.

## ***Introduction***

Hot Wax therapy is one of several methods available to the therapist of applying heat directly to the surface of the body. Paraffin Wax supplied by EMS Physio Ltd melts at between 45° and 47° C. The wax is held at a temperature just above its melting point and the part of the body being treated is either immersed in the molten wax or the wax is poured onto it. Heat is transferred from the wax to the treatment area by thermal conduction.

Although temperatures above 45° may lead to skin damage under normal circumstances, immersing a hand or foot in paraffin wax at 50° C is quite comfortable. Water or oil at the same temperature would be uncomfortable and possibly damaging. However, when the skin comes into contact with the molten wax, the wax immediately next to the skin solidifies forming a thin insulating layer. This insulating layer, which is of low thermal conductivity, lowers the rate at which heat energy is applied to the skin to a level which is safe.

The latent heat of fusion of the wax is released as the wax solidifies, therefore, applying heat to the treatment area at constant temperature. In normal treatment several layers of wax are applied and further heat is released from the wax into the skin.

Another consequence of the solid layer of wax is that moisture is prevented from being lost from the surface being treated. At the end of treatment, when the wax is peeled off, the skin is left moist and soft.

The Varitherm Wax Bath comprises a resin tank which holds the paraffin wax, surrounded by an electrically heated, thermostatically controlled water jacket. The temperature control may be set to maximum in order to provide rapid melting of the solid wax when the unit is first switched on. After almost all of the wax is melted, the temperature control is normally set to approximately 50° C so that the paraffin is just in its molten state. It is advisable to check the actual wax temperature with a suitable thermometer prior to treatment.

## ***Contraindications***

Areas with open wounds must not be treated.

Patients with skin infections as heat may increase inflammation.

Patients with reduced thermal sensation.

## ***Precautions***

Paraffin wax is inflammable. Its flash point is in excess of 200° C. As the Varitherm Wax Bath heats the wax via a water jacket, heating of the wax to dangerous temperatures is prevented. Should a fire occur involving paraffin wax, CO<sub>2</sub>, dry powder or foam extinguishers should be used. **DO NOT USE WATER.**

Wax spilt on floors can be extremely slippery. Spillages must be dealt with promptly and completely.

Paraffin wax is a petroleum hydrocarbon and its molten state will produce some fumes. Always use the Varitherm Wax Bath in a well ventilated area. When not in use always cover the tank with the lid provided.



## ***Technical Specification***

Power Input	200-240 VAC 50/60 Hz (100-120 VAC 50/60 Hz available to special order)
Power Consumption	3 kW
Protection Devices	15A circuit breakers in each supply line.
Alarm Indicator	Red Neon Lamp
Size (H x W x D)	410 x 440 x 760 mm
Water Capacity	17 litres
Wax Capacity	18 kg
Weight (empty)	23 kg
Weight (fully loaded)	58 kg
Classification (EN60601-1)	Class 1, Type B

All information on model, serial number, and month/year of manufacture is located on the rear panel.

The Varitherm Wax Bath is supplied with a lid, a thermometer (to check the wax temperature) and this manual. Wax must be purchased separately.

The Varitherm Wax Bath has been designed to meet the requirements of BS EN60601-1:2001 “Medical Electrical Equipment, Part 1: General Requirements for Safety”.

## ***Optional Accessories***

Catalogue Number	Description
LNC885	Tubular steel stand for Varitherm Wax Bath
T1A	Thermometer
P11	Paraffin Wax

## ***Installation***

Upon receipt, check for any visible damage which may have occurred in transit. If any signs of damage are found then retain all packaging material and inform the carrier and the Company or its agent from whom the unit was purchased.

If not already fitted, connect a suitable plug to the mains cable. The plug must have provision for an EARTH (GROUND) connection. The mains cable has the following colour code, BROWN is LIVE (LINE), BLUE is NEUTRAL and GREEN/YELLOW is EARTH.

The Wax Bath lid is supplied, for ease of packaging, with the handle on the reverse side. Remove the two screws holding the handle and attach it to the correct side of the lid using the same screws.

The Varitherm Wax Bath must be positioned on a flat horizontal surface or on the optional stand.

Lift the water filler cover and fill with tap water until the water level is seen to be just above the inlet hole. The water capacity is approximately 17 litres.

Fill the wax container with approximately 18 kg of paraffin wax. The wax should be broken into small lumps to aid melting. Wax supplied by EMS Physio Ltd. is strongly recommended as melting point and correct operating temperature are highly dependent on the composition of the paraffin wax.

Connect the Varitherm Wax Bath to a suitable mains outlet capable of supplying at least 13A.

The Varitherm Wax Bath is now ready for use.

## Controls and Markings

### Varitherm Wax Bath Front View

The mains on/off switch is located on the front of the Varitherm wax Bath (figure 1) and is a two-position rocker switch: up for on, down for off. It has a built-in green indicator lamp to show when the mains switch is on. It is marked with the recognised IEC Symbols for on and off. Also on the front of the unit is a red warning lamp. This lamp will illuminate if the safety thermostat has opened, indicating that the unit is too hot. This is usually because there is insufficient water in the unit. The safety thermostat can only be reset by using the pull-cord at the front of the unit (figure 1) after the temperature has returned to a safe level.

Between the warning lamp and mains switch is located the control thermostat. It is graduated in degrees Celsius.

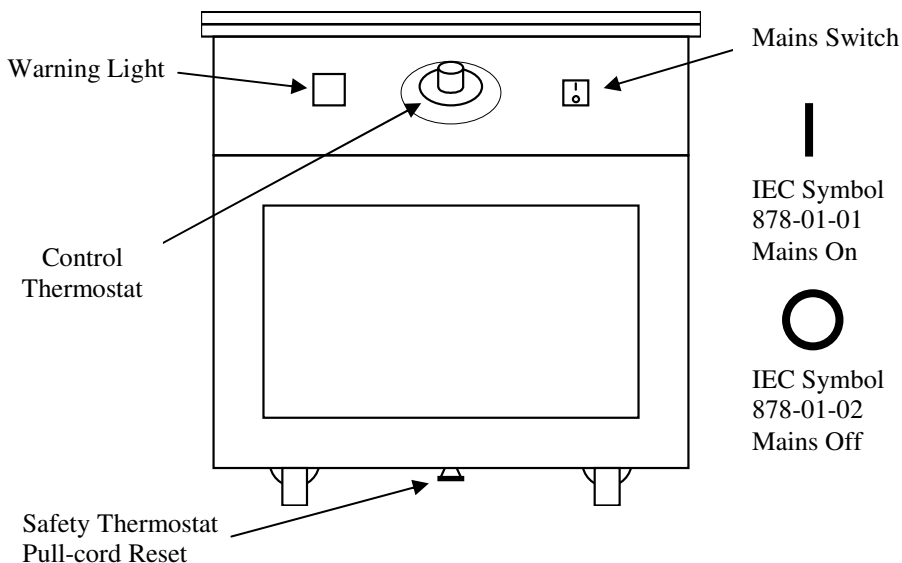

Figure 1 – Varitherm Wax Bath – Front View

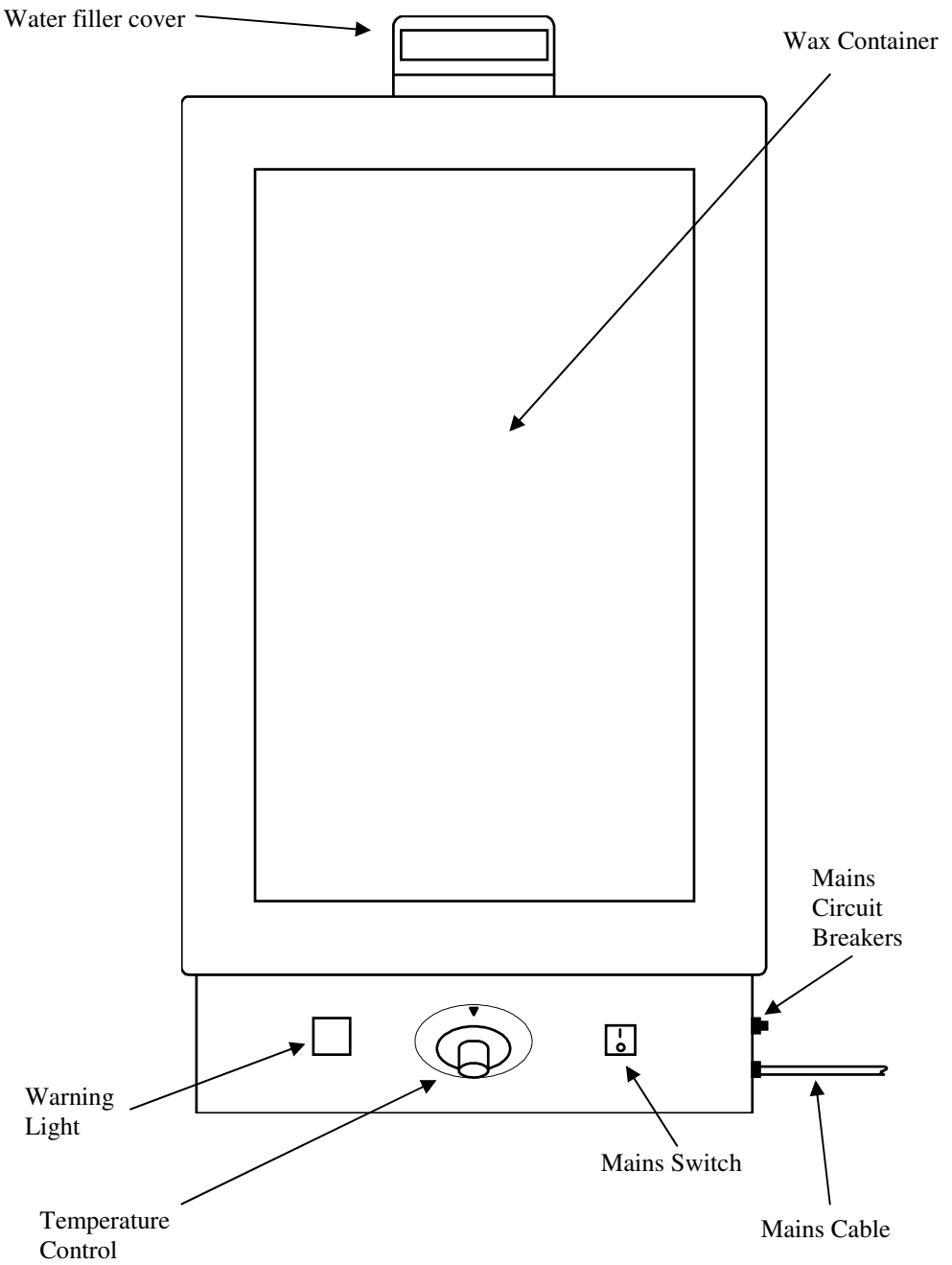

Figure 2 – Varitherm Wax Bath – Top View

The water filler cover is located at the rear of the unit (figure 2). A label reminds the user to check the water level daily.

On the rear of the unit is a label giving details of model, serial number, mains supply voltage and frequency (figure 3).

On the left side of the unit is a label showing symbols from Class B and Attention – consult accompanying documents (figure 4).

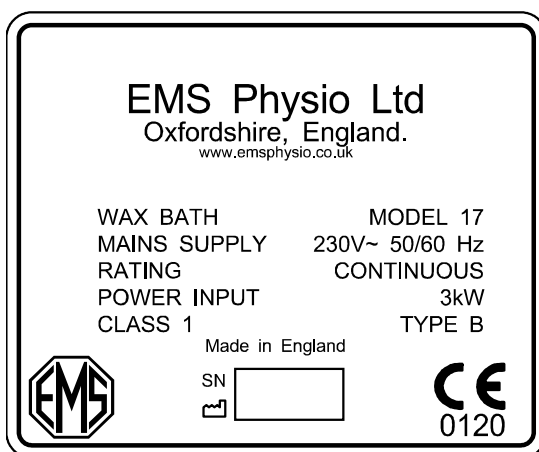

Figure 3 – Label (Rear of Unit)



Figure 4 – Label (Side of Unit)

IEC Symbol 348  
Attention, consult  
accompanying  
documents.

IEC Symbol 878-02-02  
Type B Equipment

## ***Operating Instructions***

1. Having filled the Varitherm Wax Bath with water and paraffin wax and connected it to a suitable supply as described in the installation section of this manual, switch on the unit using the mains switch which will then be illuminated.
2. Turn the Control Thermostat to maximum (60°C) and leave until almost all the wax has melted.
3. When only small pieces of solid wax remain, set the Control Thermostat to 50°C.
4. Wait for the temperature of the wax to stabilise just above its melting point (approximately 50°C). the temperature should be checked using the thermometer.
5. Inspect the area to be treated for contraindications. Wash and dry the area to be treated.
6. Immerse the part of the body to be treated in the wax for 2 or 3 seconds, and then withdraw it. A thin layer of solid wax will be formed. Repeat this procedure 5 to 10 times to produce a layer of wax about 3mm in thickness over the part of the body being treated.
7. The coating of wax is normally left in place for 15 to 20 minutes. The wax may then be peeled off and returned to the wax bath for re-use.
8. For areas of the body which cannot be immersed in the wax tank, molten wax may be carefully and slowly poured or ladled on to the area to be treated, making sure that wax that runs off the area can be collected in a suitable container.
9. After several treatments, dirt and other undesirable impurities may collect at the bottom of the wax tank. When this reaches an unacceptable level, the wax should be removed and purified using an EMS wax purifier which allows the lower layers of impure wax to be removed.
10. Daily check the water level in the wax bath.
11. Always check the wax temperature before use.

## ***Maintenance***

Each day check the water level is correct. The water level should be just above the inlet hole when viewed through the water-filler cover. If the water level becomes too low the safety thermostat will operate and cut off the mains supply to the heating element. The red warning lamp will light. Refill with water to the correct level and pull the reset cord at the bottom of the unit (figure 1). This will reset the safety thermostat and the red warning light will go out.

The mains circuit breakers are located adjacent to the mains cable entry at the front right of the unit. Should the mains switch not be illuminated when in the on position, check to see if either of the circuit breakers has tripped. To reset the circuit breakers push them in firmly. If resetting the circuit breakers does not correct the fault, examine the fuse in the mains plug (if fitted). If neither replacing the fuse in the mains plug nor resetting the mains circuit breakers rectifies the fault then qualified service personnel should be contacted.

***Circuit Description*** - Refer to the Wax Bath Model 17 Circuit Diagram on Page 21.

The mains supply is applied to the unit through 15A circuit breakers in both live and neutral connections. The mains on/off switch has an integral green lamp to show when the power is on.

The heating element is rated at 3 kW and carries a safety cut-out thermostat in a tube close to the element. The safety thermostat is set to open at 75°C. The red warning lamp is wired across the safety thermostat so that it will be illuminated should it open. The safety thermostat has a manual reset which can only be activated when the temperature has fallen below 60°C and is accessed by the pull-cord at the front of the unit.

The control thermostat is a capillary type with its sensor located in a tube away from the heating element. This thermostat controls the temperature of the water and therefore the wax in normal use. It is adjusted to have a maximum setting of 60°C.

## *Disassembly and Assembly*

### **Replacing the Wax Tank (24-50A)**

1. Remove the two grub screws securing the wooden surround.
2. Remove the wooden surround (24-50B).
3. Remove the wax tank (24-50A).
4. Inspect the rubber seal (15-45) around the edge of the copper tank and replace if damaged or perished.
5. Insert the new tank, replace the wooden surround and secure with the two screws.

### **Replacing the Safety Thermostat (24-57)**

1. Remove the four screws which secure the front cover and remove the cover itself.
2. Remove the two M3 screws which secure the fibreglass plate to the metal bracket attached to the element.
3. Remove the red and black wires from the screw terminals on the thermostat.
4. Withdraw the safety thermostat from its tube.
5. Fit the new thermostat, connect the red and black wire to the screw terminals on the thermostat.
6. Check the water level is correct and set the control thermostat to 60°C. Set the safety thermostat to its maximum position.
7. Connect the mains supply and wait for the water to reach the set temperature.
8. Reduce the setting of the safety thermostat until it opens and the red warning light comes on.
9. Increase the setting of the safety thermostat to about 75°C and pull the reset cord. The warning light should go out.
10. Switch off the unit and replace the front cover with its four fixing screws.



## **Element/Thermostat Assembly**

The original heating element and cut out thermostat for Wax Baths prior to serial number 70074 are no longer available.

For these earlier Wax Baths the complete Element/Thermostat assembly part number C17-41 must be used whenever either the heating element or cut out thermostat are required to be replaced.

## **Fitting of replacement element/Thermostat Assembly**

For wax baths serial number 70074 onwards the element assembly part number 60-66 and cut out thermostat part number 24-83 are direct replacements for the original components.

For wax baths prior to serial number 70074 follow the procedure below for installation of the combined replacement element assembly part number C17-41 (this assembly includes the cut out thermostat).

1. Remove the wires linking the old assembly to the wiring loom and unscrew the assembly from the tank.
2. Fit the new element assembly C17-41 to the wax bath tank.
3. Undo the two M3 screws holding the reset plate and swing it to the right exposing the screw for the left hand terminal in the thermostat housing.
4. Refit the black wire to the left hand terminal and refit the reset plate into position (the red wire from the 3 way terminal to the cut-out thermostat has been fitted at the factory).
5. The previously removed red wire (step 1) must now be extended by unwrapping part of its length from the wiring loom to enable it to be plugged into the tag on the new element assembly.
6. Refer to the instructions on page 16 for the safety thermostat temperature setting.

**LNC884 VARITHERM WAX BATH**

<u>Part No.</u>	<u>Description</u>	<u>Qty</u>
40-85	WAX BATH	1
7-1	HANDLE BLACK NYLON	1
A17-23	WAX BATH LID	1
OM884EN	OPERATING MANUAL	1
T1A	THERMOMETER	1

**40-85 WAX BATH**

<u>Part No</u>	<u>Description</u>	<u>Qty</u>
10-41	PLUG TOP 13A	1
15-45	RUBBER EXTRUSION	182cm
17-30B	SWITCH ROCKER GREEN	1
17-49	TERMINAL BLOCK 4WAY	1
19-3	CABLE TIE T18R	3
2-24	SPIRAP 6mm	100cm
2-73	CASTOR 2" RUBBER TYRE	4
24-50A	WAX BATH INNER TANK	1
24-50B	WOODEN SURROUND C/T	1
24-51	BACK NUT 2-1/4" BSP	1
24-52	BACK NUT 1/2" GAS	1
24-53B	WATER FILLER MOULDED	1
24-55	THERMOSTAT CAPILLARY	1
24-55B	ESCUTEON BEZEL	1
24-57	POCKET THERMOSTAT	1
24-59	BALL VALVE SEAT	1
24-83	THERMAL CUT OUT	1
31-66	CHROME SPACER	2
33-18	SCREW M3 x 10 PAN HD	3
33-25	SCREW M4 x 8 C/SUNK	1
33-30	SCREW M4 x 10mm	10
33-31	SCREW M4 x 10mm	4

33-37A	SCREW M4 x 20mm	1
33-46A	SCREW M5 x 40 C/SUNK	2
33-48	SETSCREW M6 x 30 HEX	2
<u>Part No</u>	<u>Description</u>	<u>Qty</u>
33-50	SCREW M8 x 16 HEX HD	8
34-1	WASHER M3 PLAIN	6
34-22	WASHER M3 BERYLLIUM	3
34-23	WASHER M4 BERYLLIUM	21
34-24	WASHER M6	2
34-34	M8 INTERNAL S/PRF	4
34-42	NUT M3 HEX	6
34-43	NUT M4	3
34-45A	NUT M8	4
35-30	WASHER 2BA HEAVY	2
35-4	SCREW 2BA x 3/8 HEX HD	2
36-10	GRUB SCREW 4BA x 1/4	2
36-7	SCREW 4BA x 1/4 C/SUNK	1
39-37	WASHER 5/16 HEAVY	8
39-47	FIBRE WASHER 38mm OD	1
60-66	ELEMENT MODIFIED	1
7-18A	NEON INDICATOR	1
7-4A	HANDLE HAF 525	1
A17-15	FRONT PANEL	1
A17-28	KNOB ASSEMBLY THERMOSTAT	1
A17-32	COPPER WASHER	1
A17-35	SPACER	1
A17-38	THERMOSTAT RET.BRK'T	1
A17-39	THERMOSTAT RESET PT.	1
A17-43	INSULATOR	1
A17-50	LABEL SET	1
B17-4	FRONT CASTOR PLATE	1
B17-5	REAR CASTOR PLATE	1
B17-9	COPPER WATER TANK	1
C126	CABLE BLACK MAINS	350cm
C17-6	OUTER CASE	1
C184	P CLIP RICHCO NE6	1
C39	CABLE BLACK 63/0.2	190cm
C41	CABLE RED 63/0.2	162cm

C59	NYLON BRAIDED CORD	30cm
C82	CABLE GRN/YEL 63/0.2	54cm
G6	GROMMET 3028 3/8"	1
<u>Part No</u>	<u>Description</u>	<u>Qty</u>
G30	CABLE STRAIN RELIEF	1
L106	L E N LABEL	1
L57A	LABEL "PER No. BATCH"	1
L78	LABEL "EARTH SYMBOL"	1
L94	LABEL "POWER"	1
P2	PLASKLIP 5/16	1
R10	POP RIVET TSP/D 435	2
R18	RIVET BUTT HD NO.16	14
S144	HEAT TRANSFER COMPOUND	25ml
S35	SLEEVING YELLOW 3mm	5cm
T100	TAG, RING YELLOW	2
T11A	TERMINAL 42095-1	1
T28	TERM BOOT 154509-2	17
T40A	2BA BLUE RING TAG	3
T50	TERMINAL 41729-2	16
T67	BRASS TAB	1

**Spare Parts Only:-**

B17-37	WATER FILLER ASSEMBLY
C17-42	COMPLETE CABLE ASSEMBLY

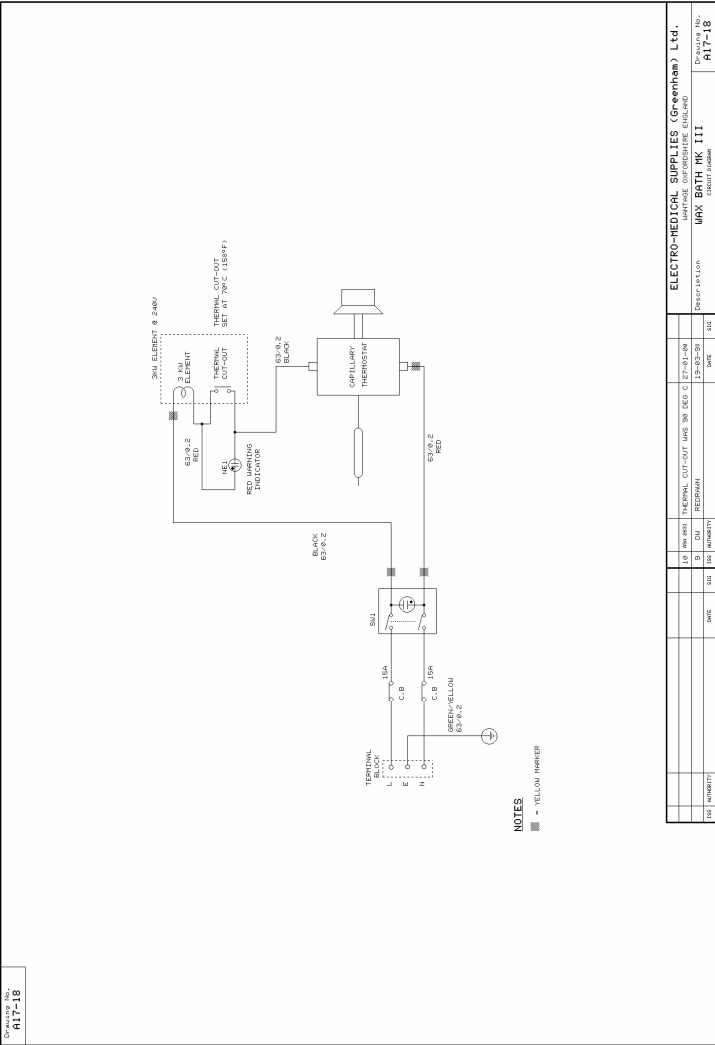

**Varitherm Wax Bath Model 17 Circuit Diagram**

## ***EMC Tables***

1	<b>Guidance and manufacturers declaration – electromagnetic emissions</b>		
2	The Varitherm Wax Bath is intended for use in the electromagnetic environment specified below. The customer or the user of the Varitherm should assure that it is used in such an environment.		
3	<b>Emissions Test</b>	<b>Compliance</b>	<b>Electromagnetic environment - guidance</b>
4	RF emissions CISPR 11	Group 1	The Varitherm generates negligible RF emissions (switching of thermostat). Therefore, its RF emissions are very low and are not likely to cause any interference in nearby electronic equipment.  The Varitherm is suitable for use in all establishments other than domestic and those directly connected to the public low-voltage power supply network that supplies buildings used for domestic purposes.
6	RF emissions CISPR 11	Class A	
7	Harmonic emissions IEC 6100-3-2	Class A	
8	Voltage fluctuations Flicker emissions IEC 61000-3-3	Complies	

**Guidance and manufacturers declaration – electromagnetic immunity**

The Varitherm Wax Bath is intended for use in the electromagnetic environment specified below. The customer or the user of the Varitherm should assure that it is used in such an environment.

<b>Immunity test</b>	<b>IEC 60601 test level</b>	<b>Compliance level</b>	<b>Electromagnetic Environment guidance</b>
Electrostatic discharge (ESD) IEC 61000-4-2	±6 kV contact ±8 kV air	±6 kV contact ±8 kV air	Floors should be wood, concrete or ceramic tile. If floors are covered with synthetic material, the relative humidity should be at least 30%.
Electrical fast transient/burst IEC61000-4-4	±2 kV for power supply lines ±1 kV for input/output lines	±2 kV for power supply lines ±1 kV for input/output lines	Mains power quality should be that of a typical commercial or hospital environment.
Surge IEC61000-4-5	±1 kV differential mode ±2 kV common mode	±1 kV differential mode ±2 kV common mode	Mains power quality should be that of a typical commercial or hospital environment.
Voltage dips, short interruptions and voltage variations on power supply input lines  IEC 61000-4-11	<5% <i>UT</i> (>95% dip in <i>UT</i> ) For 0,5 cycle 40% <i>UT</i> (60% dip in <i>UT</i> ) For 5 cycles 70% <i>UT</i> (30% dip in <i>UT</i> ) For 25 cycles <5% <i>UT</i> (>95% dip in <i>UT</i> ) For 5 sec	<5% <i>UT</i> (>95% dip in <i>UT</i> ) For 0,5 cycle 40% <i>UT</i> (60% dip in <i>UT</i> ) For 5 cycles 70% <i>UT</i> (30% dip in <i>UT</i> ) For 25 cycles <5% <i>UT</i> (>95% dip in <i>UT</i> ) For 5 sec	Mains power quality should be that of a typical commercial or hospital environment. If the user of the Varitherm requires continued operation during power mains interruptions, it is recommended that the Varitherm be powered from an uninterruptible power supply.
Power frequency (50/60 Hz) Magnetic field IEC 61000-4-8	3 A/m	3 A/m	Power frequency magnetic field should be at levels characteristic of a typical location in a typical commercial or hospital environment.

NOTE *UT* is the a.c. mains voltage prior to application of the test level.

## Guidance and manufacturers declaration – Electromagnetic immunity.

The varitherm Wax Bath is intended for use in the electromagnetic environment specified below. The customer or user of the Varitherm Wax Bath should assure that it is used in such an environment.

Immunity Test	IEC 60601 Test level	Compliance level	Electromagnetic Environment Guidance
Conducted RF IEC61000-4-6	3Vrms 150kHz to 80MHz	3V	<p>Portable and mobile RF communications equipment should be used no closer to any part of the Varitherm Wax Bath, including cables, than the recommended separation distance calculated from the equation applicable to the frequency of the transmitter.</p> <p><b>Recommended separation distance</b></p> $d=3.5\sqrt{P/V_1}$
Radiated RF IEC61000-4-3	3V/m  80MHz to 2.5GHz	3V/m	<p><math>d=3.5\sqrt{P/E_1}</math> 80MHz to 800MHz</p> <p><math>d=7\sqrt{P/E_1}</math> 800MHz to 2.5GHz where P is the maximum output power rating of the transmitter according to the manufacturer and d is the recommended separation distance in metres (m).</p> <p>Field strengths from fixed RF transmitters, as determined by an electromagnetic site survey<sup>a</sup> should be less than the compliance level in each frequency range<sup>b</sup>.</p> <p>Interference may occur in the vicinity of equipment marked with the following symbol:</p> <div style="text-align: center;">  </div>

NOTE 1 At 80MHz and 800MHz the higher frequency range applies.

NOTE 2 These guidelines may not apply in all situations. Electromagnetic propagation is affected by absorption and reflection from structures, objects and people.

<sup>a</sup> Field strengths from fixed transmitters, such as base stations for radio (cellular/cordless) telephones and land mobile radios, amateur radio, AM and FM radio broadcast and TV broadcast cannot be predicted theoretically with accuracy. To assess the electromagnetic environment due to fixed RF transmitters, an electromagnetic site survey should be considered. If the measured field strength in the location in which the Varitherm Wax Bath is used exceeds the applicable RF compliance level above, the Varitherm Wax Bath should be observed to verify normal operation. If abnormal performance is observed additional measures may be necessary, such as re-orienting or relocating the Varitherm Wax Bath.

<sup>b</sup> Over the frequency range 10kHz to 80MHz, field strengths should be less than 3 V/m.



**Recommended separation distances between portable and mobile RF communications equipment and the Varitherm Wax Bath**

The Varitherm Wax Bath is intended for use in an electromagnetic environment in which radiated RF disturbances are controlled. The customer or user of the Varitherm can help prevent electromagnetic interference by maintaining a minimum distance between portable and mobile RF communications equipment (transmitters) and the Varitherm Wax Bath as recommended below, according to the maximum output power of the communications equipment.

	<b>150kHz to 80MHz <math>d=3.5\sqrt{P/V_1}</math></b>	<b>80MHz to 800MHz <math>d=3.5\sqrt{P/E_1}</math></b>	<b>800MHz to 2.5GHz <math>d=7\sqrt{P/E_1}</math></b>
0.01	0.12	0.12	0.23
0.1	0.38	0.38	0.73
1	1.2	1.2	2.3
10	3.8	3.8	7.3
100	12	12	23

For transmitters rated at a maximum output power not listed above, the recommended separation distance  $d$  in meters (m) can be estimated using the equation applicable to the frequency of the transmitter, where  $P$  is the maximum output power rating in watts (W) according to the transmitter manufacturer.

NOTE 1 At 80MHz and 800MHz the separation distance for the higher frequency range applies.

NOTE 2 These guidelines may not apply in all situations. Electromagnetic propagation is affected by absorption and reflection from structures, objects and people.